



- 4x 
- 2x 
- 2x 

**1**



**2**

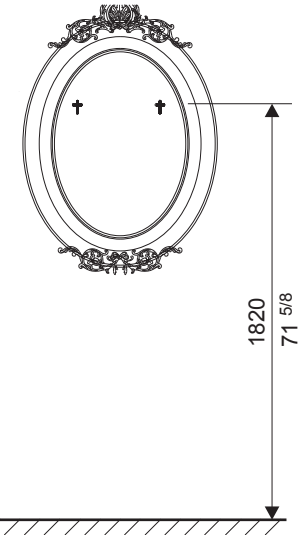
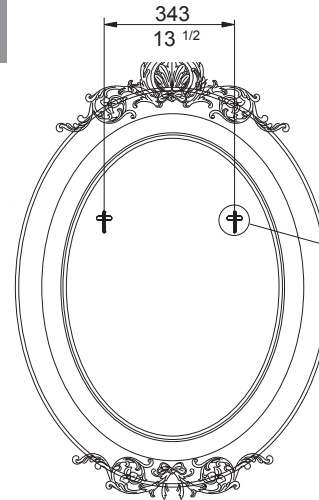